

POWER STEERING CONTROL SYSTEM (VANTREND/BOOMER)

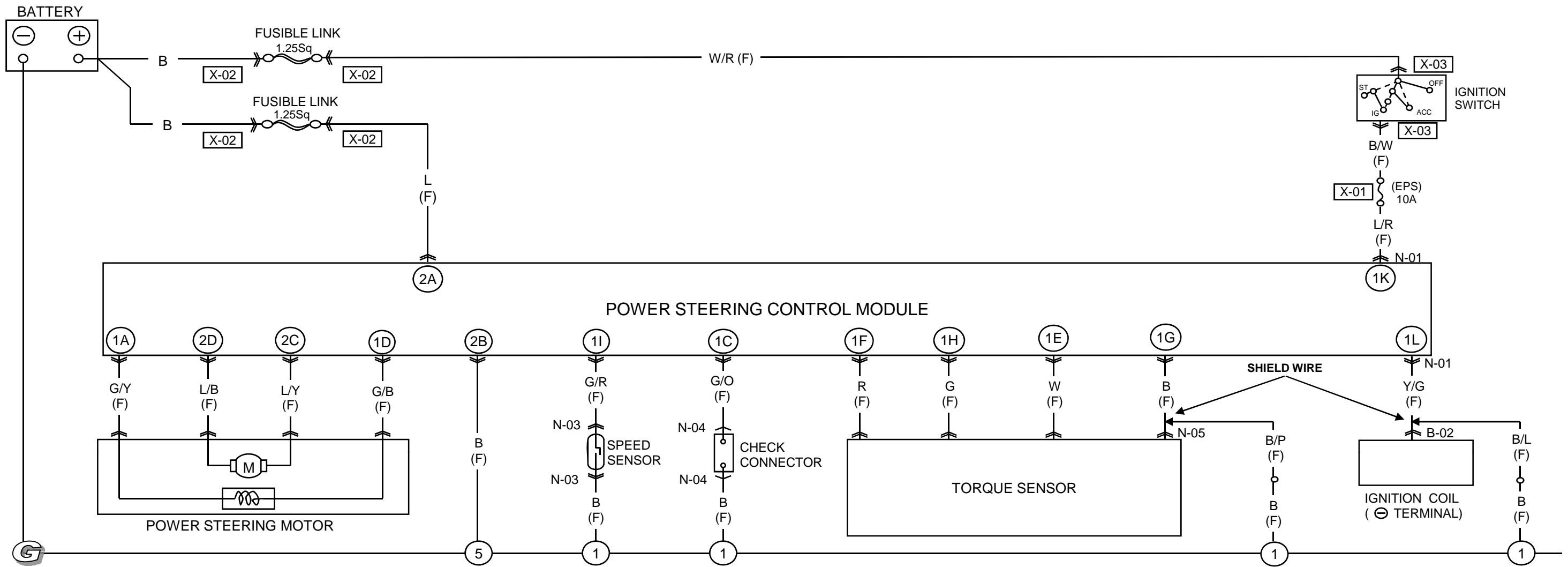

N-01 POWER STEERING CONTROL MODULE (F)

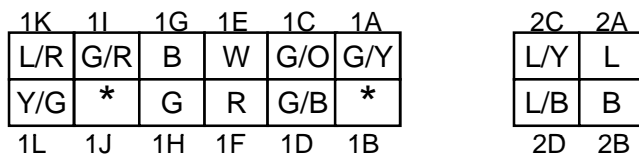

N-02 POWER STEERING MOTOR (F)



N-03 SPEED SENSOR (F)

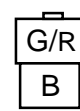

N-04 CHECK CONNECTOR (F)

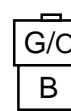

N-05 TORQUE SENSOR (F)

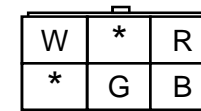

B-02 IGNITION OIL (⊖ TERMINAL) (F)



X-01 FUSE BOX (F)

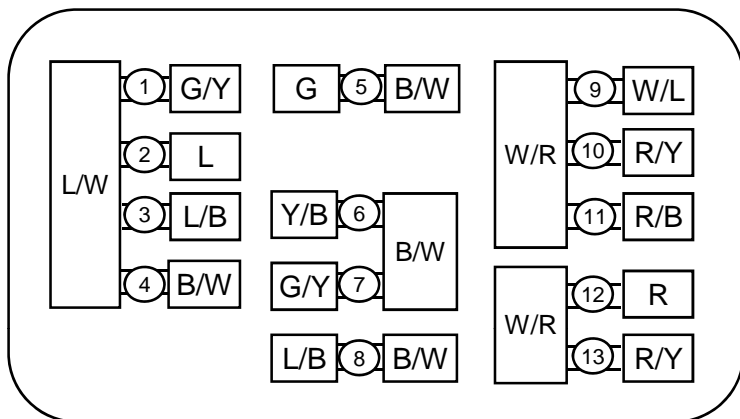

- ① DEFOG 10A
- ② WIPER 15A
- ③ HEATER, R WIPER 15A
- ④ CIGAR 10A
- ⑤ TURN 10A
- ⑥ ENGINE 10A
- ⑦ METER 10A
- ⑧ EPS 10A
- ⑨ STOP HORN 15A
- ⑩ ROOM 15A
- ⑪ TAIL 15A
- ⑫ DOOR LOCK 15A
- ⑬ POWER WINDOW 30A

X-02 FUSIBLE LINK

